

Encapsulated Interposing Current Transformer Current Interfacing



- Encapsulated current transformer.
- Tough resilient flame retardant UL-94V0.
- Temperature range -20°C to 70°C
- Accuracy class 1.0, 0.5
- Test voltage 4Kv 50Hz. 1min.
- IEC44-1, IEC185, BS3938, DIN42600
- Insulation Class E, Max 120°C
- Totally enclosed in tough, self extinguishing mouldings.
- Operating voltage 0.72KV
- Summation current transformer
- Normal secondary winding 1A or 5A

Introduction

There are C.T.s. which are interposed between the main C.T. and the burden (Load) so that the secondary current of the main C.T. is adjusted as required by the burden. When used in providing transformer differential protection, these C.T.s are also used to correct the phase shift, which may result due to particular method of connection used for the transformer windings. The main function of an interposing CT is to balance the currents supplied to the relay or others where there would otherwise be an imbalance due to the ratios of the main CTs. Interposing CTs are equipped with a ratio that can be selected by the user to achieve the balance required. As the name suggests, an interposing CT is installed between the secondary winding of the main CT and relay. They can be used on the primary side or secondary side of power transformer being protected, or both. Interposing CTs also provide a convenient method of establishing a delta connection for the elimination of zero sequence currents where this is necessary.

Compliance	: IEC 185 and BS 3938 / 1973
Burden	: 5VA or 7.5VA
Accuracy	: 0.5 or 1.0
Rated voltage	: 720V 50/60Hz
Dielectric voltage	: 4kV
Type of material	: High impact flame-retardant moulded resin
Input	: 5/5 A, 1/1A others by request.

Application

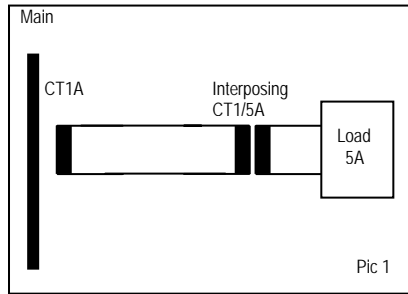

A) When the main C.T. s having rated secondary current of 1 Amp. And the burden requires a rated current of 5 Amp., an I.C.T. is used , at the load end so that the lead burden is fed by 1 Amp. Current. The lead burden on the I.C.T. is negligible as it placed very close to the burden (Pic. 1).

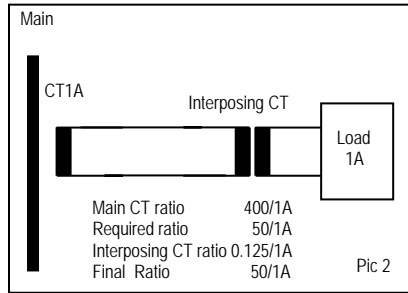

B) The arrangement suggested in 'a' above may also be used when the main C.T. is having rated secondary of 5 Amps. And the burden requires a rated current of 1 amp. In this case however, the I.C.T. of ratio 5/1 Amp will have to be placed at the main C.T. end to reduce the effect of lead burden on the main C.T. (Pic. 2).

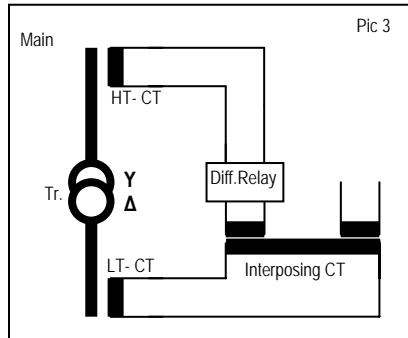

C) In the case of transformer differential protection when the main C.T. ratios do not match. If phase shift is introduced due to the mode of connections of the transformer on the H.T. and L.T. side, I.C. Ts. Can be used to correct the phase shift. It is assumed here that all main C.T.s. are star connected (Pic.3).

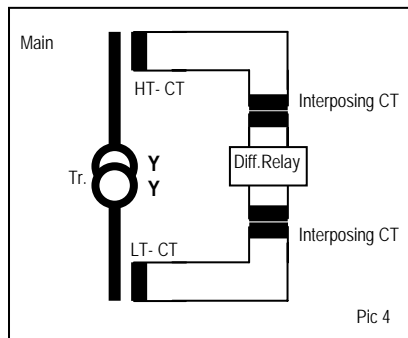

D) For suppressing zero sequence currents from the out of balance current. This is achieved by providing an additional secondary winding on I.C.Ts. which is connected in closed delta (Pic. 4).

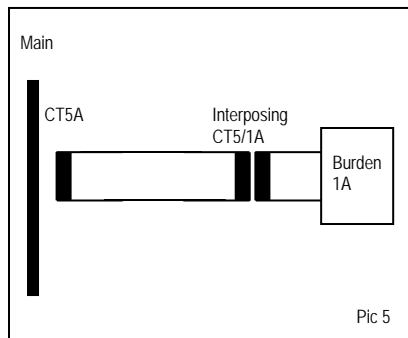

E) If high ratio is selected for the main C.T. against a low load current, I.C.T.s. may be used across the main C.T. to reduce the ratio effectively and satisfactorily cater ti the rated current requirement of the burden (Pic. 5).

In all above applications it must be borne in mind that an I.C. T. imposes burden on the main C.t. if this burden is required to be restricted to a certain value, the value must be specified to enable the manufacturer to design the I.C.T. suitably. If this value of burden (expressed in VA) is too low, it may result into an uneconomical design of the I.C.T.